

ADJUSTMENT IN HEIGHT FROM 80 TO 130
MM



BENEFITS

- The CLEMAN® range allows you to prepare the site by pre-setting the riser pedestals using the driver bit, use the screw adjuster to set the riser pedestal height, and carry out the final millimetres of adjustment using the special adjustment key.
- Performed lateral solution: 2 lateral integrated riser supports.
- A square base makes it easy to lay paving at an angle.
- Rubber damper included.
- Divisible spacers for staggered laying.
- Optimised stability: all the riser elements are mounted together.
- Cleman® accessories : 60 mm extension, side finishing plate, adjustment key and driver bit.

APPLICATIONS

- Ideal for creating paved or ceramic tiled outdoor terraces for pedestrian use only.

RESISTANCE

- Resistance to crushing test exceeds 1T.

RECOMMENDATIONS

- Terraces and patios for pedestrian use only.
- Outdoor use only.
- Always follow paving manufacturer recommendations to ensure the suitability of paving products for use with riser pedestals and the number of risers per m² to use. Qualification of compulsory "SELF-SUPPORTING" slabs, of class T7, T11 according to standard EN 1339:2004-02.
- Paving riser pedestals should be used only on stabilised level ground or on existing concrete support.
- When the riser pedestal is used at its highest position, we recommend adding a 10 mm extension to provide greater flexibility during adjustment.
- When the riser pedestal is used at its lowest position, we recommend using the rised pedestal of the next size down, adding a 10 mm extension for greater flexibility when adjusting.
- For IFU, see the website.

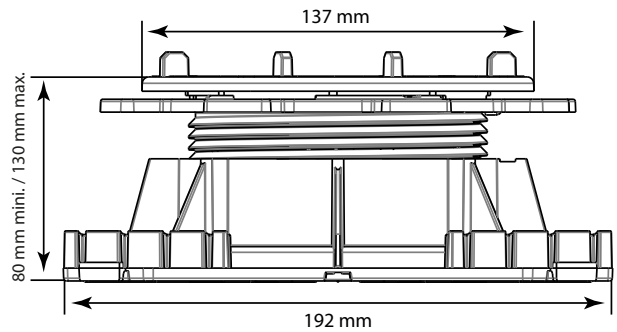

TECHNICAL DETAILS

- Material: recycled polypropylene
- Colour: black, blue nut
- Adjustable height: mini.: 80 mm / maxi.: 130 mm
- Spacer thickness: 4 mm
- Dimensions of the base: 192 mm x 192 mm - Bearing contact area: 300 cm²
- Support surface diameter: 137 mm - Bearing contact area: 100 cm²
- Weight: 493 g
- Resistance to temperature from -30°C to +60°C
- UV and frost resistant

PACKING

- Box of 20 parts (12 boxes per pallet - Stackable)